

KINDER®
Valley

^{z^z}
SNOOZIE Bedside Crib
ASSEMBLY INSTRUCTIONS

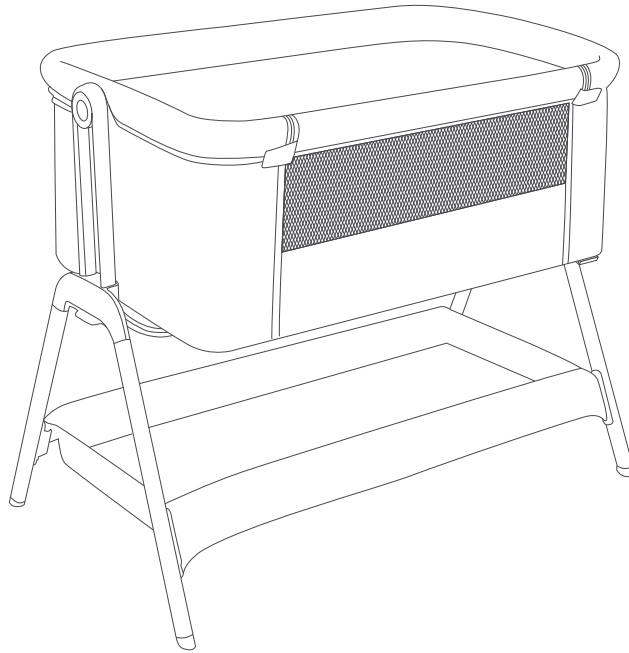

IMPORTANT! KEEP FOR FUTURE
REFERENCE

Dimensions(cm): (L)99 x (W)56.5 x (H)62-82*

Mattress Size(cm): (L)88 x (W)49

- Easy assembly • Safe & Sturdy • Six Adjustable Heights • Storage Caddy and Travel Bag Included

*Approx. measurements only. Sizes may vary.

Contact Us...

E sales@kinder-valley.com

T 0844 7744644 - Option 2

www.kinder-valley.com



SNOOZIE Bedside Crib

ASSEMBLY INSTRUCTIONS

Before you start

IMPORTANT! KEEP FOR FUTURE REFERENCE

Instructions for safe use:

WARNING – Do not use this product without reading the instructions for use first.

WARNING – This bedside crib is only suitable for adult beds with a min/max height of 53-64cm from the floor to top of the mattress.

WARNING – Adult beds with thin mattresses are not suitable with this bedside crib. Suitable mattress thicknesses for the adult mattress is a minimum 26cm/10inches.

WARNING – Only divan style beds are suitable with this bedside crib, i.e. beds without a side rail higher than the bottom of the mattress and where the width of the bed base is the same size as the mattress height. No other bed is suitable to use with the crib.

WARNING – Stop using the product as soon as the child can sit or kneel or pull itself up.

WARNING – Placing additional items in the product may cause suffocation.

WARNING – Do not place the product close to another product, which could present a danger of suffocation or strangulation, e.g. strings, blind/curtain cords, etc.

WARNING – Do not use more than one mattress in the product.

WARNING – Only use the mattress sold with this crib, do not add a second mattress on this one, suffocation hazards.

WARNING – To avoid hazards from the child's neck being caught on the top rail on the side that is next to the adult bed, the top rail must not be higher than the adult bed mattress.

WARNING – To avoid the risk of your child being strangled the attachment system to the adult's bed shall always be kept away from and out of the crib.

WARNING – Use only on firm ground which is on a horizontal level and dry.

WARNING – Do not allow young children to play unsupervised in the vicinity of the crib.

WARNING – All assembly fittings should always be tightened properly and care should be taken that no screws are loose, because a child could trap parts of the body or clothing (e.g. strings, necklaces, ribbons for babies' dummies, etc.), which would pose a risk of strangulation.

WARNING – The maximum thickness of the mattress for this product is 30mm.

WARNING – Be aware of the risk of burning cigarettes, open fires and other sources of strong heat, such as electric bar fires, gas fires, etc. in the near vicinity of the crib.

WARNING – When adjusting the tilt position, make sure the angle of the inclination of the crib base end to end (head to feet) shall not be greater than 10° or the difference between left and right height adjustment mechanisms shall not be greater than 2.

WARNING – This bedside crib should never be used in a titled position when next to the adult bed. This bedside crib can be used in a titled position only if used as a stand alone crib.

WARNING – Do not use this use this crib if any parts are missing, damaged, or broken. Contact Kinder Valley for replacement parts and instructional literature if needed. Do not substitute parts.

WARNING – Only use the included attachment to attach to an adult bed. Do not use any other attachment system.

WARNING – To prevent a suffocation hazard from entrapment, the bedside sleeper shall be properly secured to the adult bed using the attachment system.

WARNING – Ensure there is never a gap between the lower side of the bedside sleeper and the mattress of the adult bed.

WARNING – Check the tightness of the attachment system before each use by pulling the bedside sleeper in a direction away from adult bed.

WARNING – If there is any gap between the bedside sleeper and the adult bed **DO NOT** use product. Gaps should not be filled with pillows, blankets or other items.

WARNING – Fabric puckering is normal when tightening the straps when the bedside crib is being used next to an adult bed.

This Kinder Valley bedside crib conforms to BS EN1130:2019.

This Kinder Valley bedside crib is suitable from birth to approximately 6 months or when the child can sit or kneel or pull itself up. It is intended to be used by one child at a time.

We recommend you use any Kinder Valley mattress size 88cm x 49cm x 3cm.

Use only on firm ground which is on a horizontal level and dry.

Do not let young children play unsupervised in the vicinity of the crib.

Cleaning Instructions:



Machine washable at 40 degrees.



Do not bleach.



Do not tumble dry.



Iron on low heat.



Do not dry clean.

SNOOZIE^{zz} Bedside Crib Mattress

ABOUT YOUR MATTRESS

Assembly:

To close the zip, with the aid of a paper clip, hook one end of the paper clip over the zip slider.

The slider has been removed for safety reasons.

Warnings:

WARNING - The zip puller has been removed for safety reasons, when the mattress is in use ensure the zip is fully closed and the zip slide is not in view.

WARNING - The zip can be opened (for example when the cover needs to be removed for washing) with the aid of a paper clip by hooking one end of the paper clip over the zip slider.

WARNING - Do not use the product if any part is broken; torn or missing and use only spare parts approved by manufacturer.

WARNING - Do not use more than one mattress in the cot.

WARNING - Be aware of the risk of burning cigarettes, open fires and other sources of strong heat, such as electric bar fires, gas fires, etc. in the near vicinity of the mattress.

This Kinder Valley bedside crib mattress conforms to BS EN16890:2017 and BS7177:2008 + A1:2011.

This Kinder Valley bedside crib mattress is suitable from birth to approximately 6 months.

The mattress is supplied with the crib, do not use another mattress.

Care Instructions:

Cover may be sponged clean with warm water.

Machine wash only if necessary.

Stretch into shape whilst damp.

Do not use biological detergents.

Do not tumble dry, iron or expose to heat.

Do not immerse crib mattress or fillings in water.

Ensure mattress is completely dry before use.

You may notice an odour when opening the sealed bag, this is due to the manufacturing process and is completely safe and normal, if smell is overwhelming, air before use.

Fixtures & Fittings

CHECK THAT YOU HAVE ALL FIXTURES AND FITTINGS BEFORE ASSEMBLY, AND ENSURE THEY ARE NOT BROKEN.

A x1 Bedside Crib

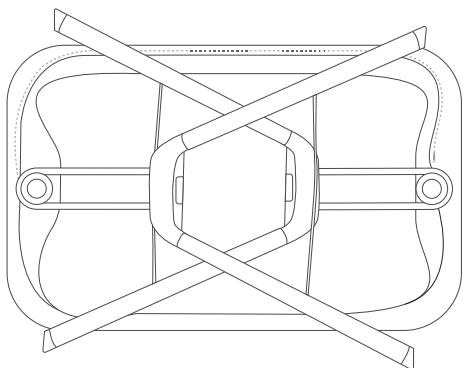

B x1 Mattress

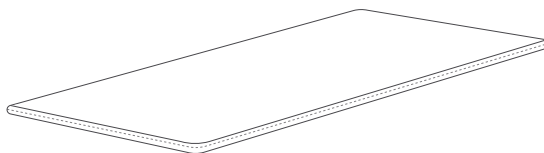

C x1 Side Iron Strap Attachment Frame

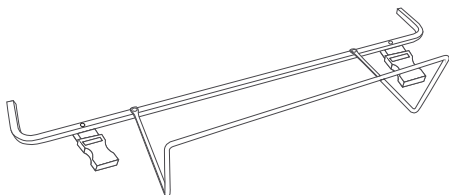

D x1 Storage Caddy

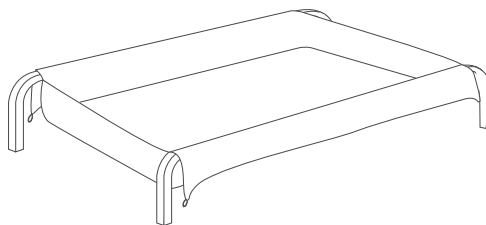

E x2 Straps

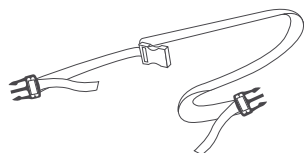

Number of people to assemble:



One adult is required to assemble this item.

How to Assemble your Bedside Crib.

Step 1

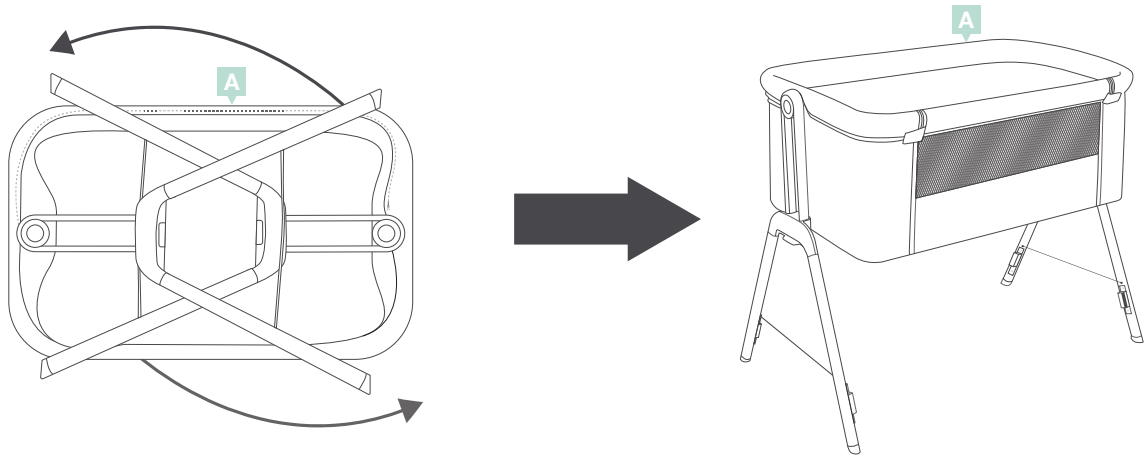

Unfold the legs on part **A** and stand it up.

Step 2



Insert x1 Side Iron Frame **C** into the horizontal brackets on the legs of the bedside crib frame **A**.

IMPORTANT - RETAIN FOR FUTURE REFERENCE

Step 3

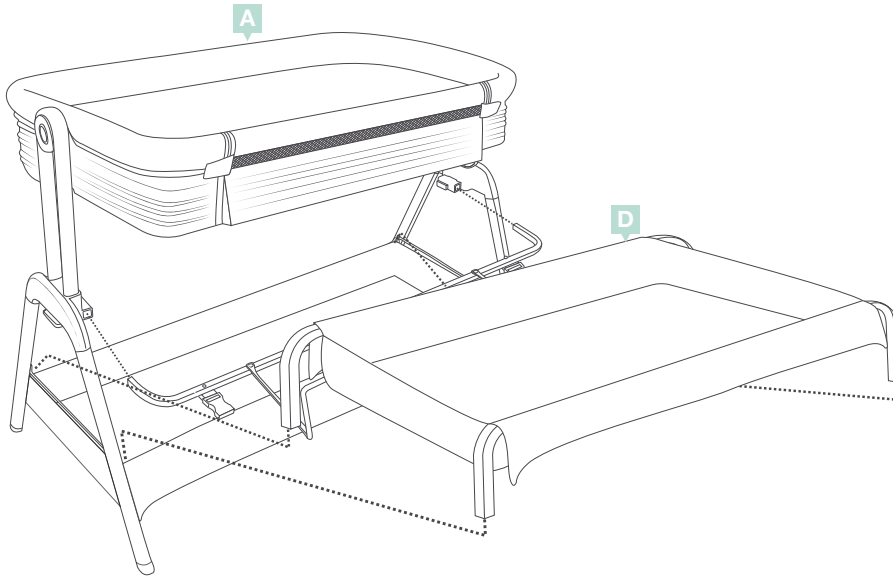

Insert x1 Storage Caddy **D** into the Vertical brackets on the legs of the bedside crib frame **A**.

Step 4

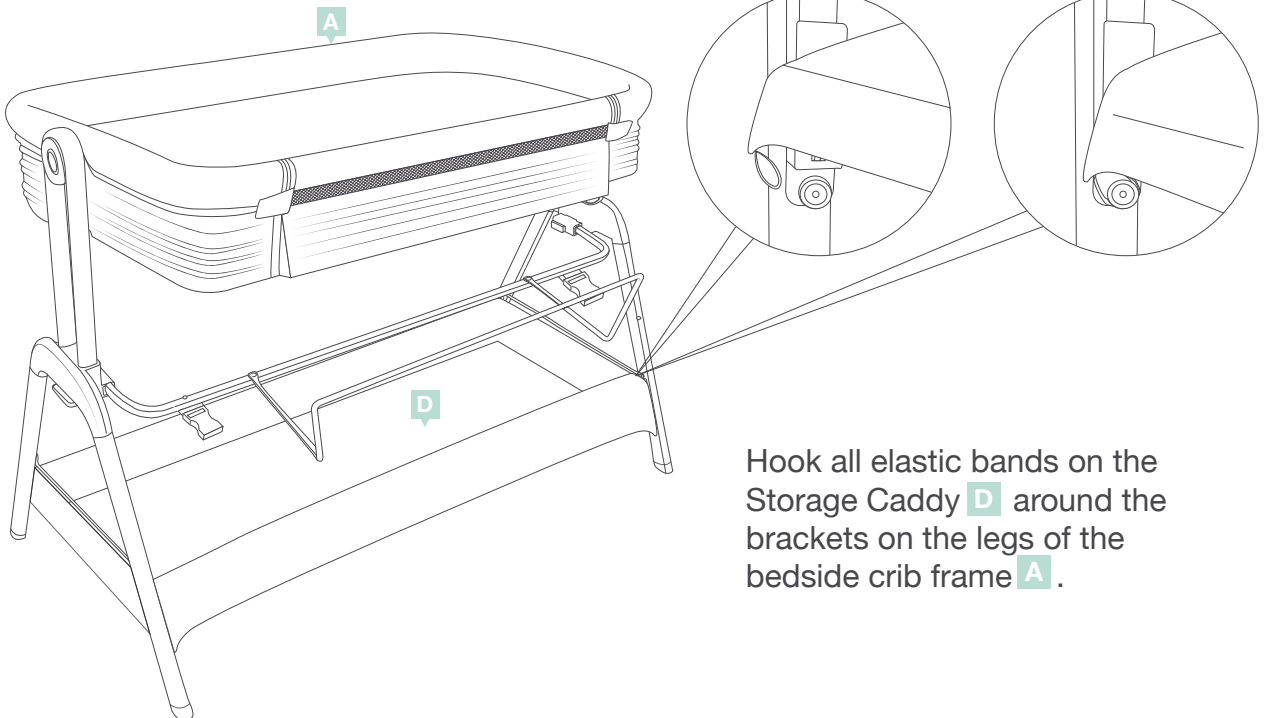

Hook all elastic bands on the Storage Caddy **D** around the brackets on the legs of the bedside crib frame **A**.

IMPORTANT - RETAIN FOR FUTURE REFERENCE

Step 5

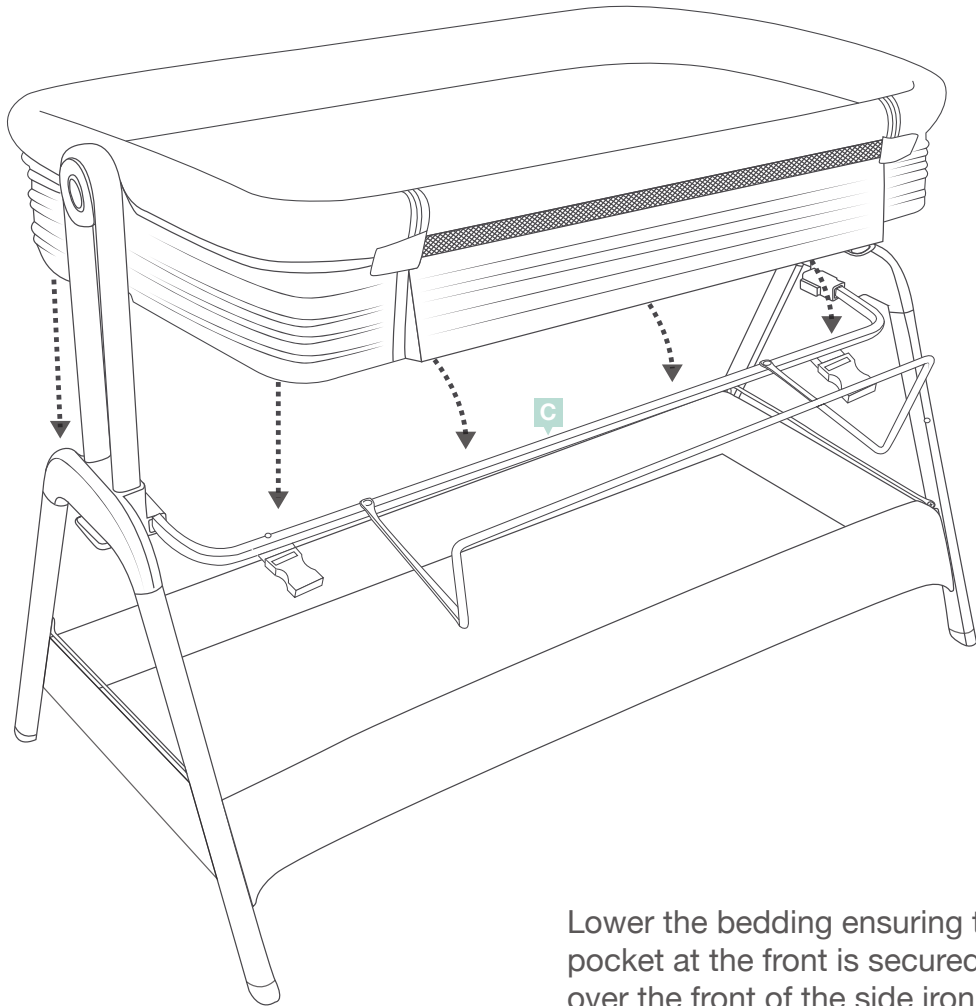

Lower the bedding ensuring the pocket at the front is secured over the front of the side iron frame **C**.

Insert mattress **B**.

Step 6

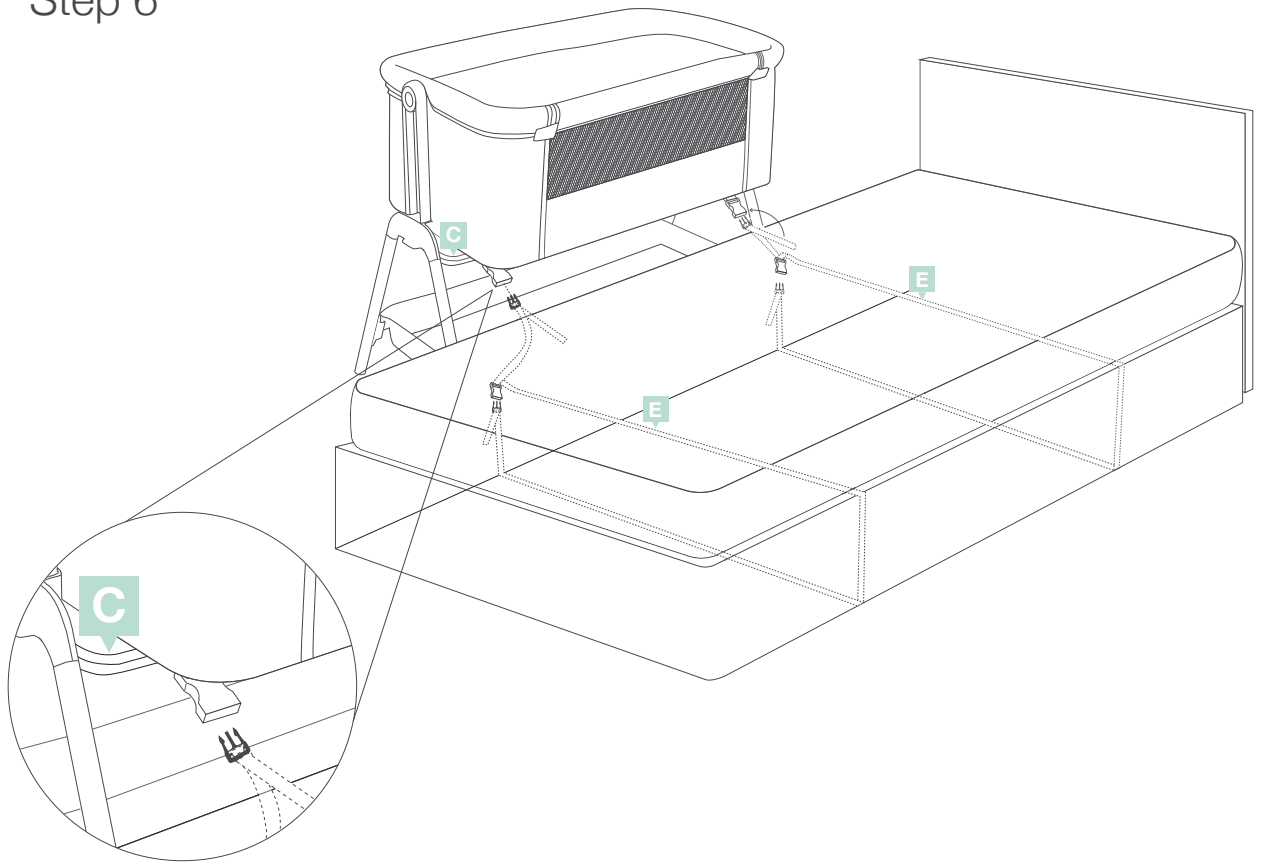

To secure your bedside crib to your bed, firstly ensure that the bottom of the mesh opening is level to the top of adult mattress. You can do this by adjusting the height of the crib up or down with the height adjustment mechanisms either side of the crib.

Then using X2 Straps **E**, connect the pronged end of the buckle on to the Side Iron Attachment Frame **C** then feed the straps under the adult bed mattress and then under the adult bed base. Pull straps to tighten, ensuring there is no gap between the bedside crib and the adult bed, check that the straps are correctly positioned and tightened by pulling the crib by the top of the legs away from the bed and retightening all straps.

How to Adjust the Height of your Bedside Crib.

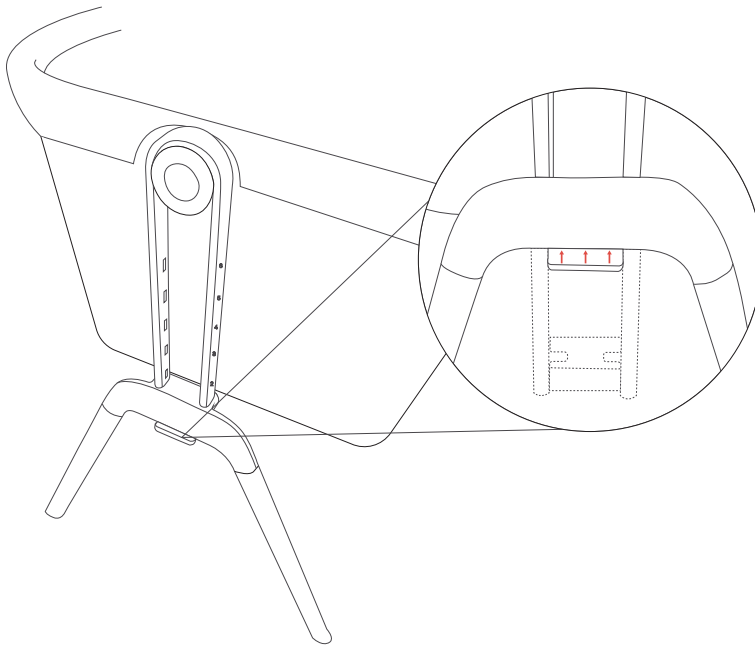

To adjust the height of your bedside crib use the push buttons either side of the crib as shown in the diagram, ensuring that the cribs clicks into place when at the level desired.

WARNING – This bedside crib should never be used in a tilted position when next to the adult bed.

How to lower the the side of your Bedside Crib.

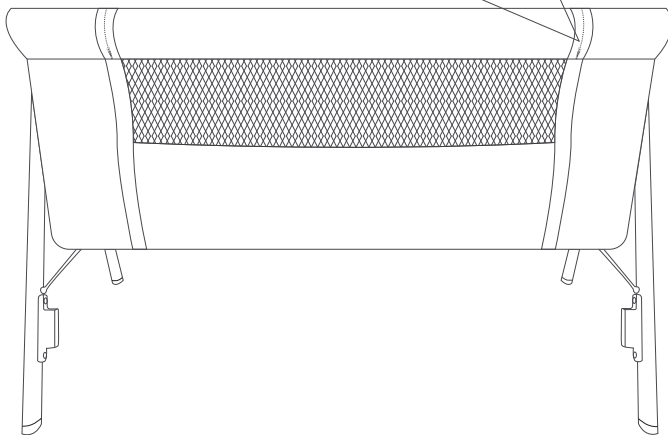
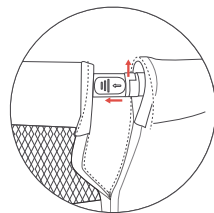

Firstly unzip both sides.

Then simultaneously push the buttons inwards and lift, this should release the catch and allow you to drop the side down.

To raise, clip back in place and zip up both zippers.

DANGER – Always completely raise the side when not attached to the adult bed.